

508 II

09/2018 ->

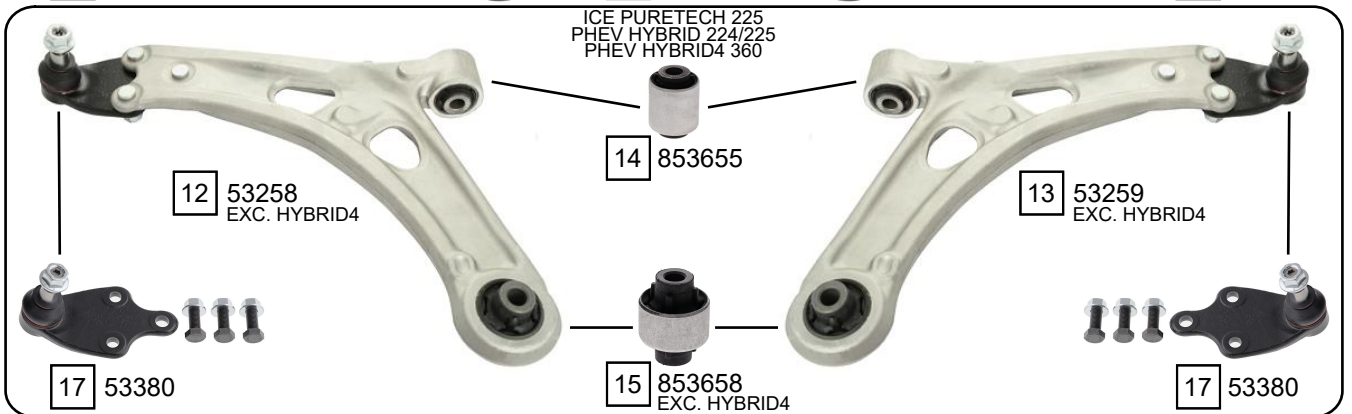
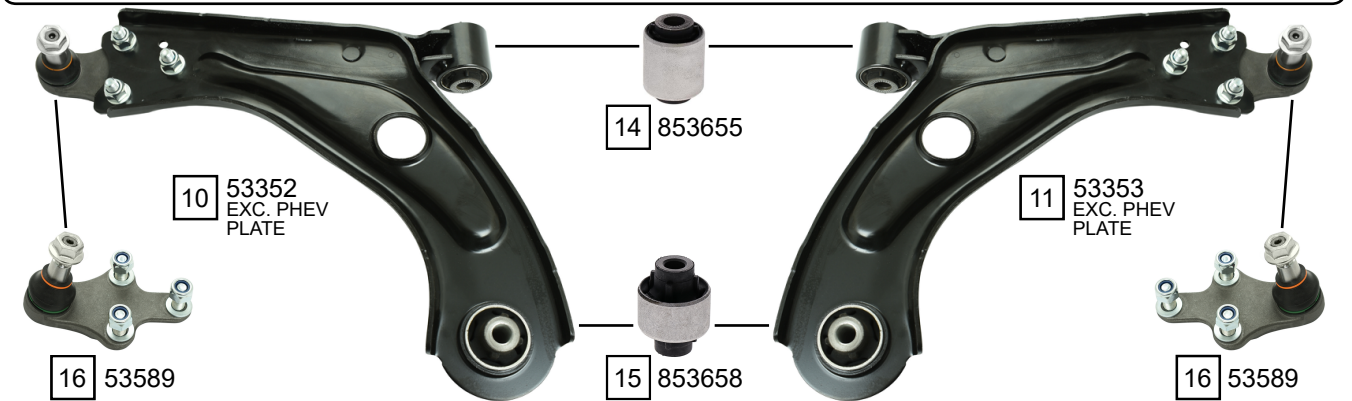
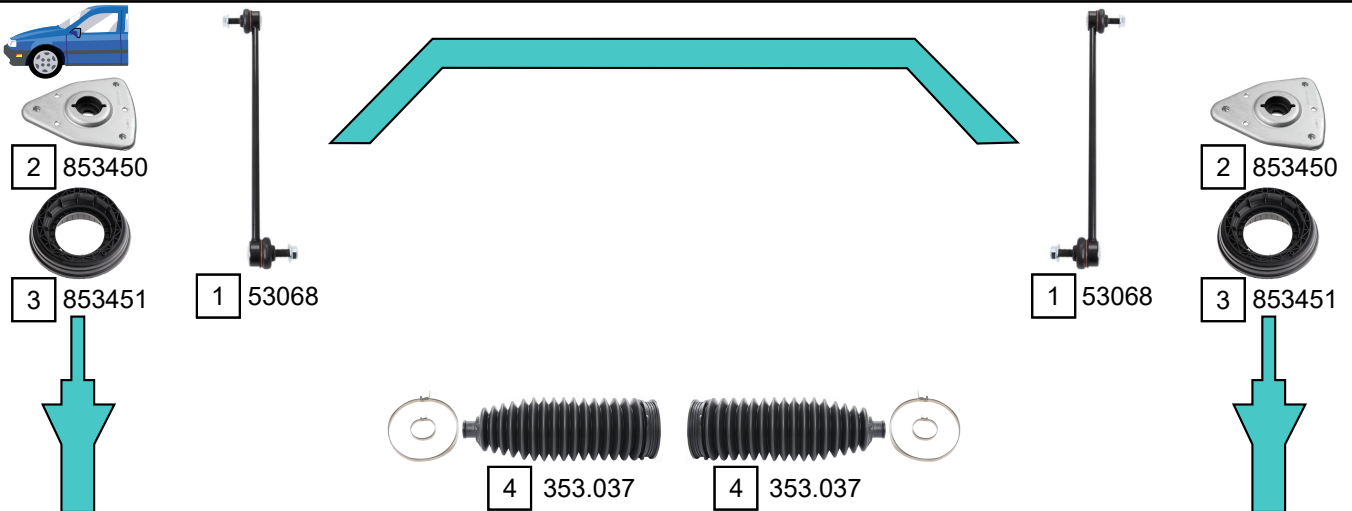

Ref.	Sidem Ref.	Description	OE-number	Measures	Ref.	Sidem Ref.	Description	OE-number	Measures
1	53068	stabiliser link	98 090 457 80	L:335	10	53352	TCA left wbj	98 227 612 80 S1	c:16.5
2	853450	strut mount	98 004 797 80	di:16	11	53353	TCA right wbj	98 227 611 80 S1	c:16.5
3	853451	bearing	98 175 924 80	do:126	12	53258	TCA left wbj	98 150 146 80 S2	c:16.6
4	353.037	steering rack gaiter	16 108 175 80	D:51 d:12 L:186	13	53259	TCA right wbj	98 150 143 80 S2	c:16.6
5	53730	tie rod end left	16 108 177 80	c:14.5 th:FM14X1.5R	14	853655	silentblock for TCA	96 760 321 80	di:14.3 do:43.4
6	53731	tie rod end right	16 108 178 80	c:14.5 th:FM14X1.5R	15	853658	silentblock for TCA	98 163 803 80	di:14.2 do:50
7	53118	axial joint	16 108 176 80	th:MM14x1.5R L:225	16	53589	ball joint	98 034 340 80	c:16.5
8	53130	tie rod end left	16 372 806 80	c:14.5 th:FM14X1.5R	17	53380	ball joint	98 153 962 80	c:16.6
9	53131	tie rod end right	16 372 807 80	c:14.5 th:FM14X1.5R					