

208 I (CA_, CC_)

05/2012 - 03/2020

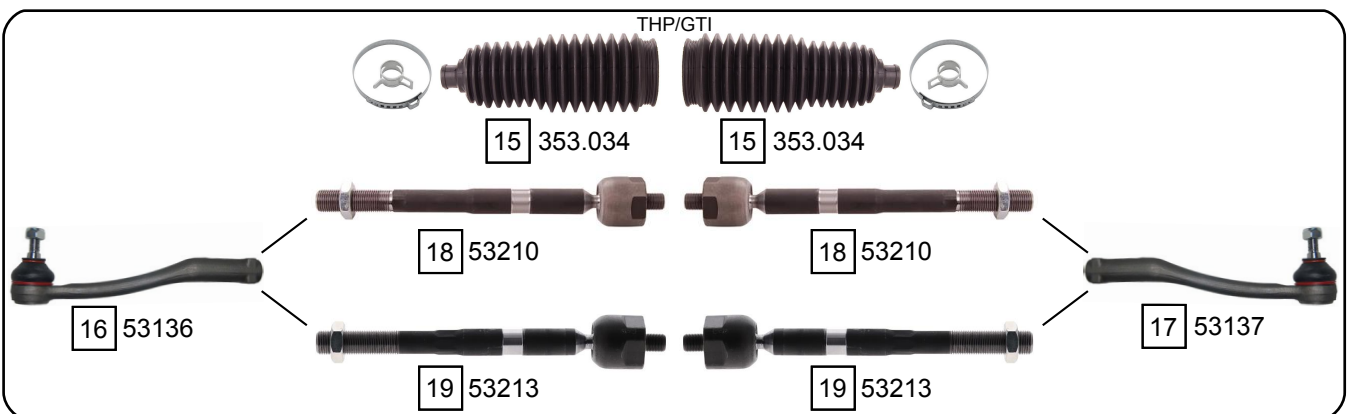
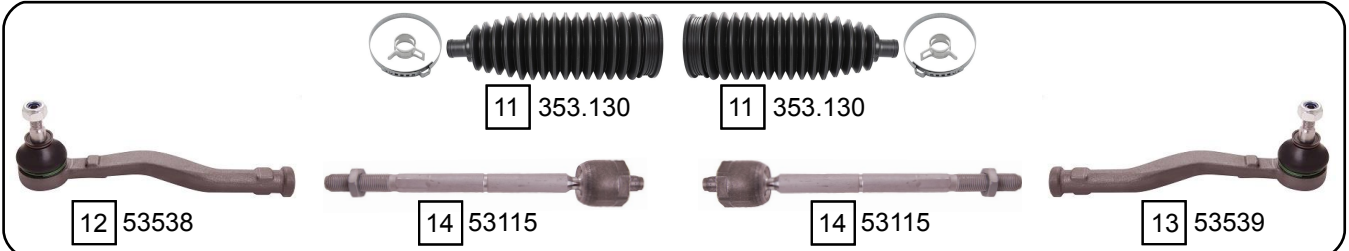
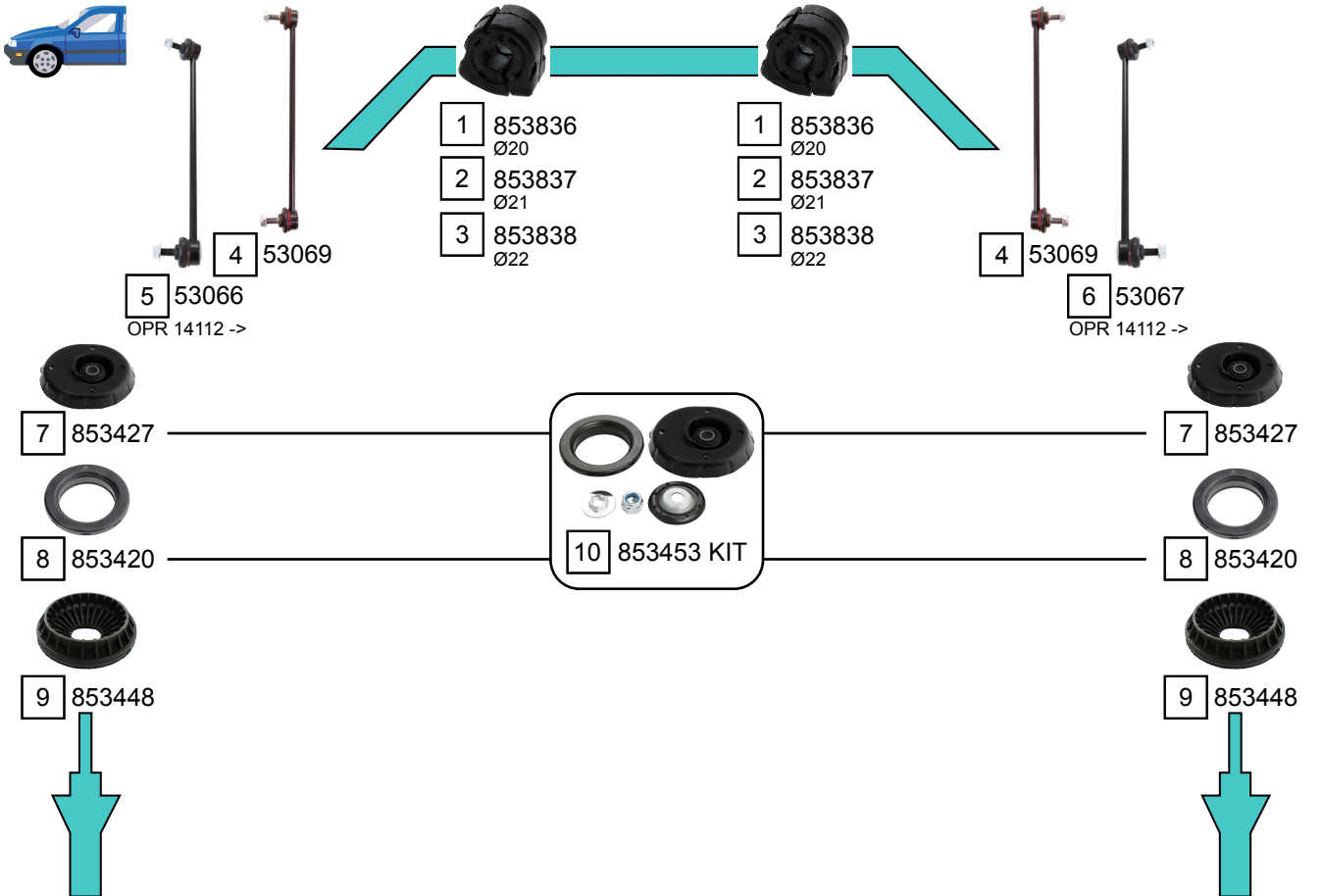

Ref.	Sidem Ref.	Description	OE-number	Measures	Ref.	Sidem Ref.	Description	OE-number	Measures
1	853836	stabilizer mounting	5094 C1	di:15	11	353.130	steering rack gaiter	16 080 254 80	D:52 d:13 L:198
2	853837	stabilizer mounting	5094 C2	di:16.5	12	53538	tie rod end left	16 080 251 80	c:12.1 th:FM14X1.5R
3	853838	stabilizer mounting	5094 C3	di:17	13	53539	tie rod end right	16 080 252 80	c:12.1 th:FM14X1.5R
4	53069	stabilizer link	5087 71	L:335	14	53115	axial joint	16 080 253 80	th:MM12X1R L:225
5	53066	stabilizer link left	5087 69	L:330	15	353.034	steering rack gaiter	4066 80	D:51 d:16 L:185
6	53067	stabilizer link right	5087 68	L:330	16	53136	tie rod end left	3817 67	c:12.1 th:FM16X1.5R
7	853427	strut mount	5038 G6	di:14.3 do:66.5 L:28.5	17	53137	tie rod end right	3817 68	c:12.1 th:FM16X1.5R
8	853420	bearing	5035 27	di:65 do:99.5 L:20	18	53210	axial joint	16 086 521 80	th:MM12X1R L:230
9	853448	strut mount	5033 C3	di:33 do:106 L:47	19	53213	axial joint	16 111 586 80	th:MM12X1R L:215
10	853453 KIT	strut mount kit	5038 G6 S1	di:14					